

# 1625B-TAB Series MatTop Chain

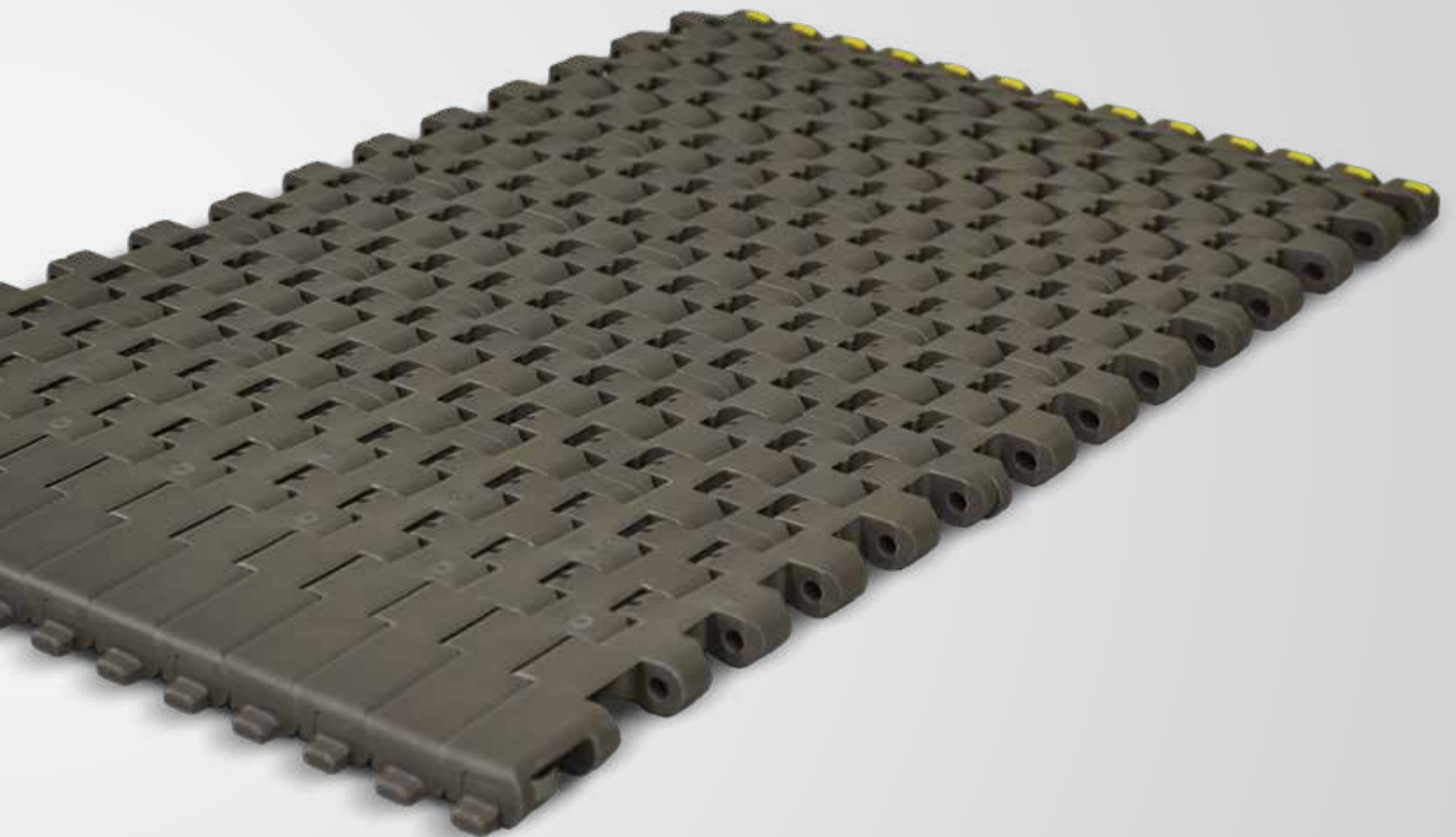

# Contents

Safety Considerations/Introduction .....	2
Chain Selection .....	4
Carry Section Wearstrips.....	8
Return Section Wearstrips .....	11
Drive and Idler .....	12
Nose-Over Transfers .....	17
Assembly and Disassembly.....	22

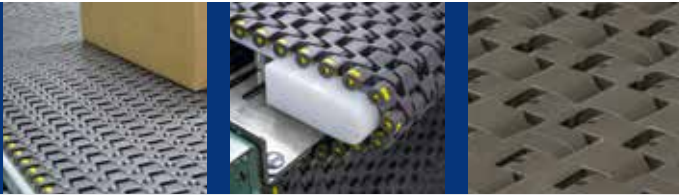

## Safety Considerations

---

### Product Safety

Products designed and manufactured by Rexnord are capable of being used in a safe manner; but Rexnord cannot warrant their safety under all circumstances. Purchaser must install and use the products in safe and lawful manner in compliance with applicable health and safety regulations, laws and general standards of reasonable care; and if purchaser fails to do so, purchaser shall indemnify Rexnord from any loss, cost or expense resulting directly or indirectly from such failure.

### Safety Devices

Products are provided with only safety devices identified herein. It is the responsibility of purchaser to furnish appropriate guards for machinery parts in compliance with MSHA or OSHA Standards, as well as any other safety devices desired by purchaser and/or required by law; and if purchaser fails to do so, purchaser shall indemnify Rexnord from any loss, cost or expense resulting directly or indirectly from such failure.

# Introduction

Rexnord® 1625B-TAB Side-flexing MatTop® Chain is the industry's leading 1 in. (25.4 mm) pitch conveying chain for high strength, transfer efficiency, and tight radius design features in curve applications. This chain provides numerous features and benefits to the designer, builder, and the end user, including:



1625B-TAB MatTop Chain

- Ultra-tight 1.5:1 (radius to width) compression ratio and compact 180° curve which more efficiently uses floor space allowing tighter, more flexible conveyor curve capabilities
- Highest working load – 200 lbs. (890 N) of any 1 in. (25.4 mm) pitch side-flexing chain
- Small pitch and scalloped bottom allow for efficient nose-over transfers, allowing for inline self-clearing performance of even the smallest packages
- Handles larger variety of packages on one conveyor
- Protects light weighted, sustainable packaging while improves throughput and operational efficiency
- Tight mesh design provides maximum safety
- Excellent product handling and low operational costs based on the proven Rexnord MatTop design

Available in assembled-to-width sizes with a minimum of 12 in. (305 mm) and increments of 3 in. (76 mm) and facilitates the use of a nose-over transfer; the Rexnord 1625B-TAB MatTop chain is ideal for case handling applications as a substitute for roller, skate wheel, powered roller, powered belt, and line shaft conveyors. Available sprocket sizes are 16, 18 and 21 tooth.

This manual includes chain dimensions, basic conveyor design considerations, and installation recommendations. Following the suggestions outlined in this manual will ensure proper operation of the conveyor to provide the optimal product handling and optimum chain life. This manual contains information that is specific to the Rexnord 1625B-TAB MatTop chain and should be used in conjunction with the Rexnord Engineering manual (8rxEM-en).

# Chain Selection

## Basic Chain Dimensions

### Chain Features

- Chain Pitch: 1.00 in. (25.4 mm)
- Thickness: 0.625 in. (15.9 mm)
- Minimum side-flex radius: 1.5 times the chain width (Radius at inside edge of chain to chain width as shown below)
- Minimum back-flex radius: 1.00 in. (25.4 mm)
- Standard chain material: HP™, High Performance acetal
- Standard pin material: Wear resistant polyester
- Direction of chain travel: Bi-directional (side-flexes in only one direction)
- Nose-over diameter: 1.56 in. (40 mm)

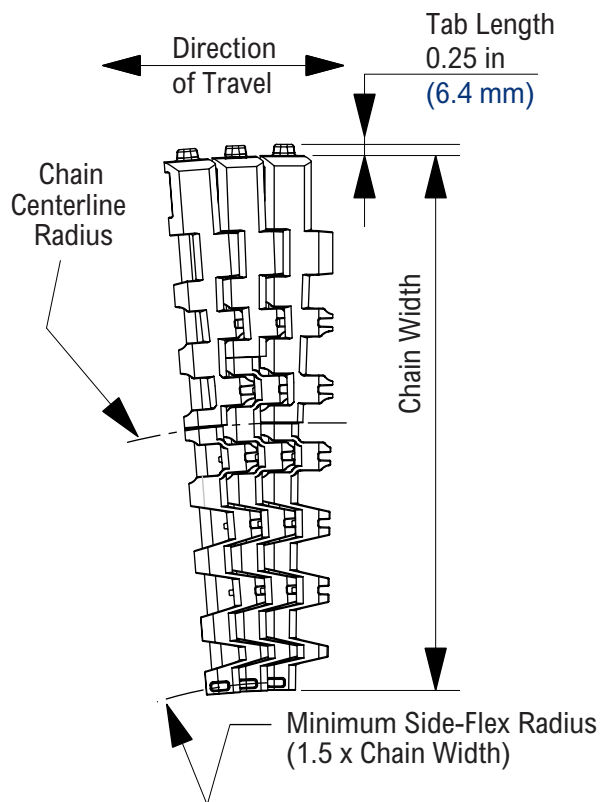

1625B-TAB Minimum Side-Flex Radius

### General Notes:

- The 1625B-TAB MatTop Chain is bi-directional, therefore either a right- or left-handed curve can be achieved with this chain
- The 1625B-TAB MatTop Chain is designed to side-flex in one direction only, therefore for "S" type conveyors, two chains with a nose-over transfer are recommended, as shown on page 13
- The design criteria that apply to standard Rexnord TableTop or MatTop chain also apply to Rexnord 1625B-TAB MatTop chains. Criteria such as wearstrip selection, lubrication, and catenary are the same as found in the Rexnord Engineering Manual (8rxEM-en)

# Chain Selection

## Basic Chain Dimensions - 1625B-TAB

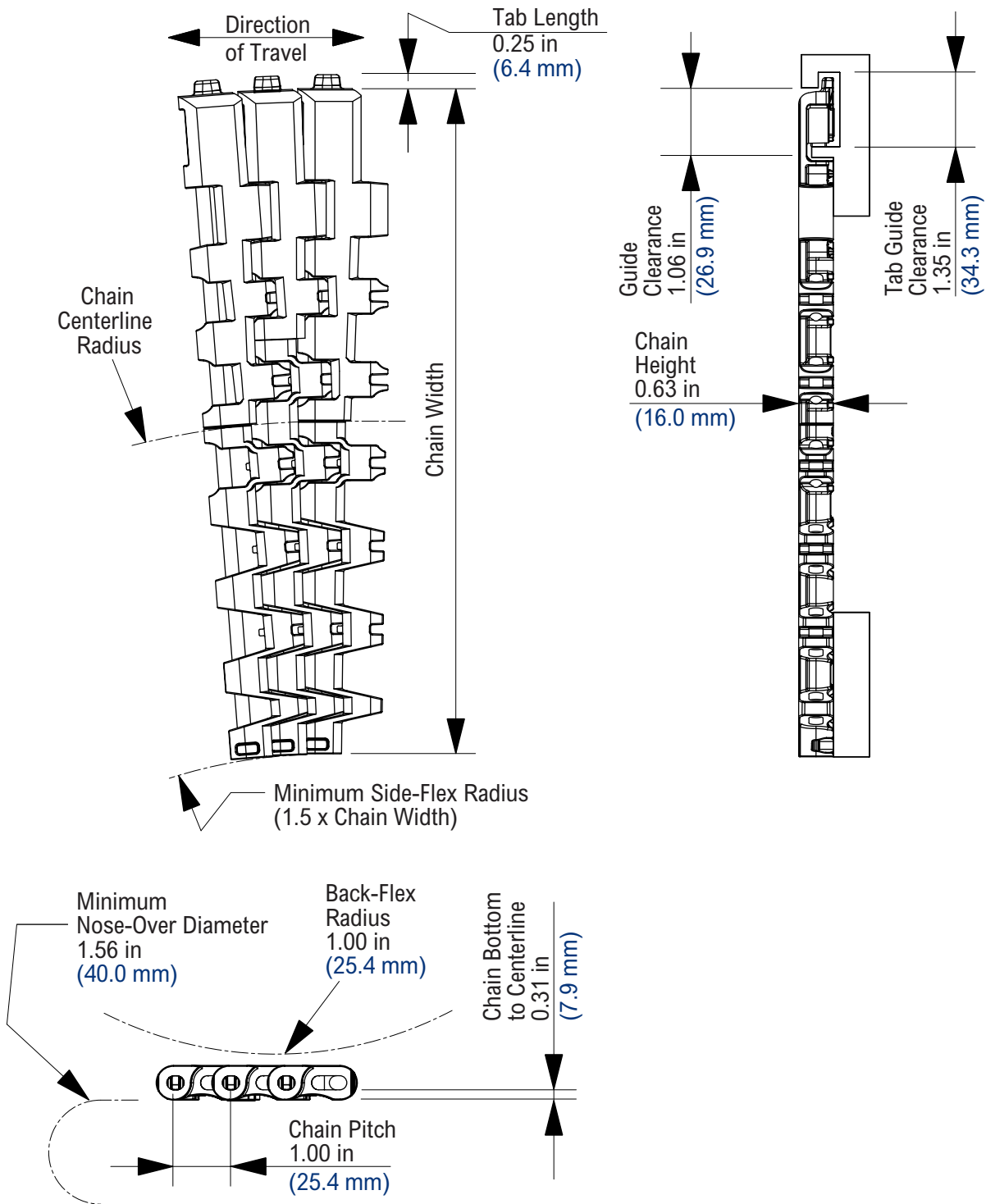

# Chain Selection

## Basic Chain Dimensions

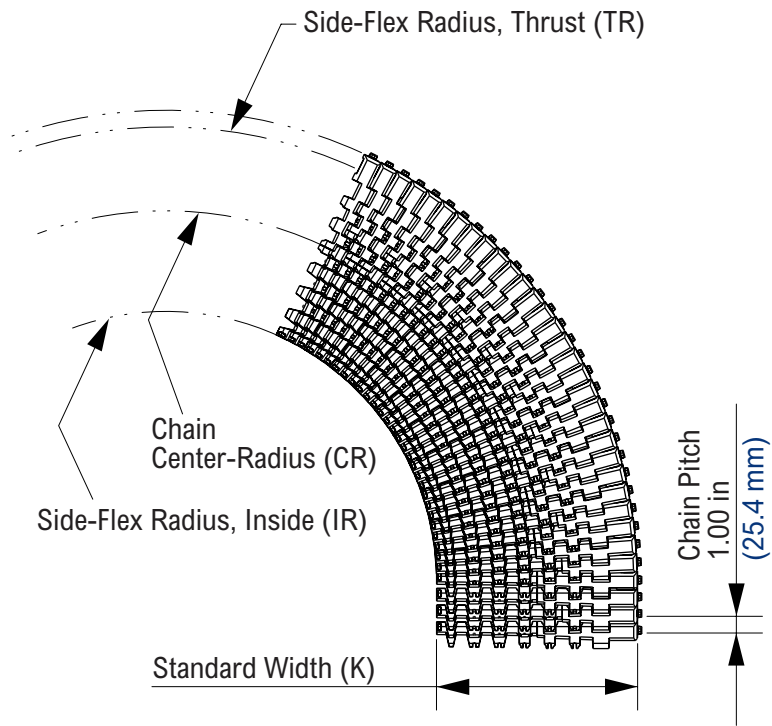

## 1625 Chain Dimensions

Chain Width (K)		Side-Flex Radius Inside (IR)		Chain Center Radius (CR)		Side-Flex Radius Thrust (TR)	
in	mm	in	mm	in	mm	in	mm
12	304.8	18	457.2	24	609.6	29	736.6
15	381	22.5	571.5	30	762	36.5	927.1
18	457.2	27	685.8	36	914.4	44	1117.6
21	533.4	31.5	800.1	42	1066.8	51.5	1308.1
24	609.6	36	914.4	48	1219.2	59	1498.6
27	685.8	40.5	1028.7	54	1371.6	66.5	1689.1
30	762	45	1143	60	1524	74	1879.6
33	838.2	49.5	1257.3	66	1676.4	81.5	2070.1
36	914.4	54	1371.6	72	1828.8	89	2260.6

# Chain Selection

## Basic Chain Dimensions

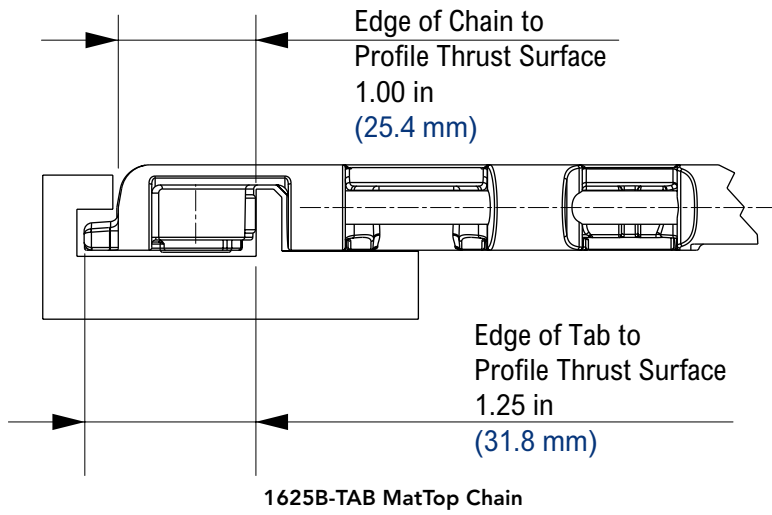

## Specifying and Part Number Nomenclature



## HP 1625B-TAB - 21

<b>Chain Material:</b> HP™ (High Performance Material)	<b>Chain Style:</b> 1625B-TAB (Bearing every other pitch)	<b>Chain Widths:</b> 12 in (304.8 mm) (minimum) 3 in (76.2 mm) (increments)
---	---	---

# Carry Section Wearstrips

---

## Recommendations for Corners and Straights

- UHMWPE support wearstrips are recommended
- Nylatron material is recommended for corner support track
- Recommended wearstrip thickness is 0.75 in. (19.05 mm) minimum. Thicker wearstrips can be used if desired
- All sharp edges of wearstrips, including corner tracks, should be chamfered to ensure smooth chain movement. Recommended contact surface finish of wearstrips is 32 to 125  $\mu$ -in Ra (0.8 to 3.2  $\mu$ -m Ra) for best wear performance
- Inside edges of straight and corner sections should contain a lead-in or chamfer for a smooth transition
- If center wearstrips are required due to product loading, they can be staggered to distribute chain wear
- Offset rail, serpentine and chevron patterns are recommended to maximize chain life because they provide uniform wear across the full width of the chain
- The wearstrips under each chain on horizontal conveyors must be level and even with each other

## General Recommendations:

- Minimum recommended straight section between the last corner and the drive shaft is 30 in. (762 mm)
- Minimum recommended straight section between the first corner and the idler shaft is 12 in. (304.8 mm)
- Carry wearstrips should end 1.00 in. (25.4 mm) from the drive or tail shaft as shown on page 15
- Return wearstrips should end 3 to 6 in. (75 to 150 mm) from the bottom of the tail sprockets

# Carry Section Wearstrips

## Recommendations for Corners and Straights

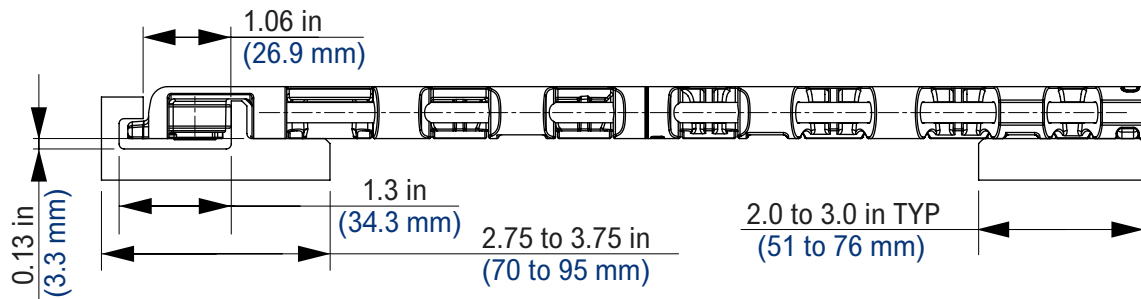

1625B-TAB Typical Straight Carry Configuration – One Piece Construction

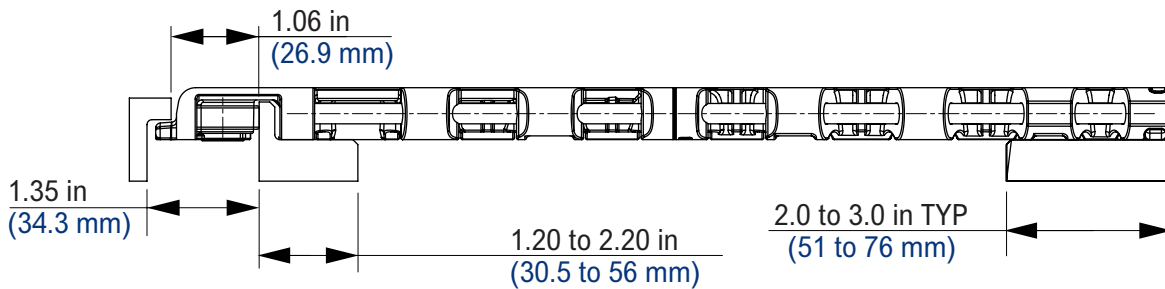

1625B-TAB Typical Straight Carry Configuration – Two Piece Construction

## Edge Guide Dimensions in Corners

### Rexnord 1625B-TAB MatTop Chain

- Must be retained in the corner with the type of edge guide shown
- Nylatron material recommended

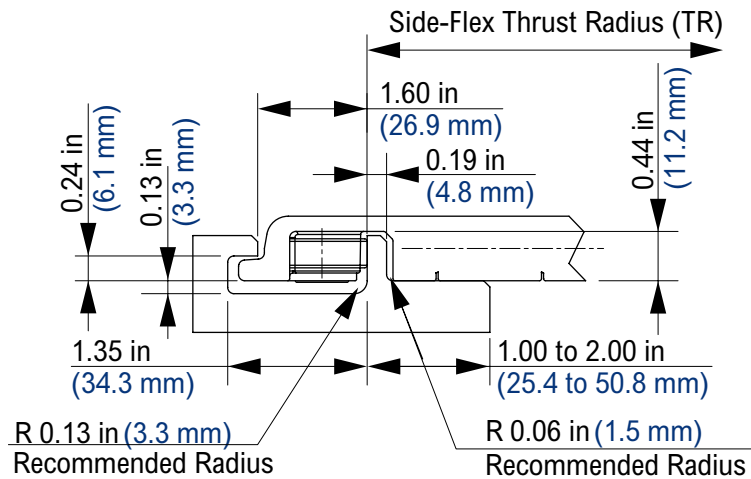

# Carry Section Wearstrips

## Spacing in Curves and Straights for Bearing Chain

All wearstrips should be evenly spaced as shown below and the number required is based on the table below.

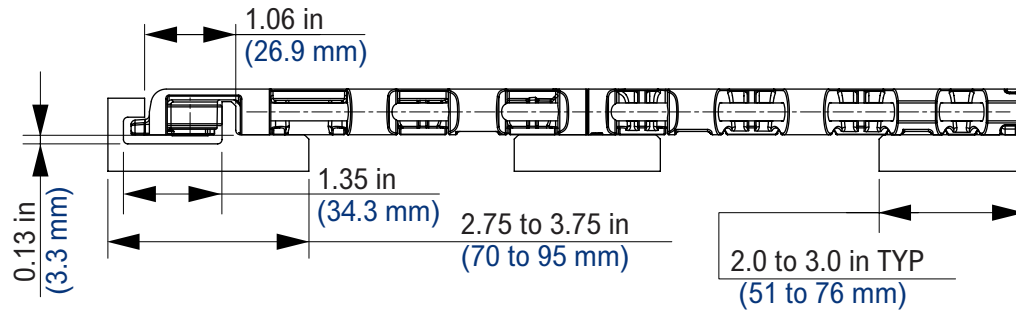

## Spacing in Curves and Straights

All wearstrips should be evenly spaced as shown above and the number required is based on the table below.

## Wearstrip Quantities and Locations

Chain Width		Inside	Middle	Outside
in	mm			
12	304.8	1	1	1
15	381	1	1	1
18	457.2	1	2	1
21	533.4	1	2	1
24	609.6	1	3	1
27	685.8	1	3	1
30	762	1	4	1
33	838.2	1	4	1
36	914.4	1	5	1

# Return Section Wearstrips

## Recommendations

- UHMWPE return tracks are recommended
- Bearing should be tracked in return as well
- All sharp edges of wearstrips, including corner tracks, should be chamfered to ensure smooth chain movement. Recommended contact surface finish of wearstrips is 32 to 125  $\mu$ -in Ra (0.8 to 3.2  $\mu$ -m Ra) for best wear performance
- Inside edges of straight and corner sections should contain a lead-in or chamfer for a smooth transition
- Center chain support is recommended for chain widths larger than 21 in. (533.4 mm)
- Roller returns are not recommended with the 1625B-TAB MatTop Chain



**CAUTION** In nose-over transfer applications it is very critical to ensure chain is tracked in the entire return section.

## Dimensions and Spacing

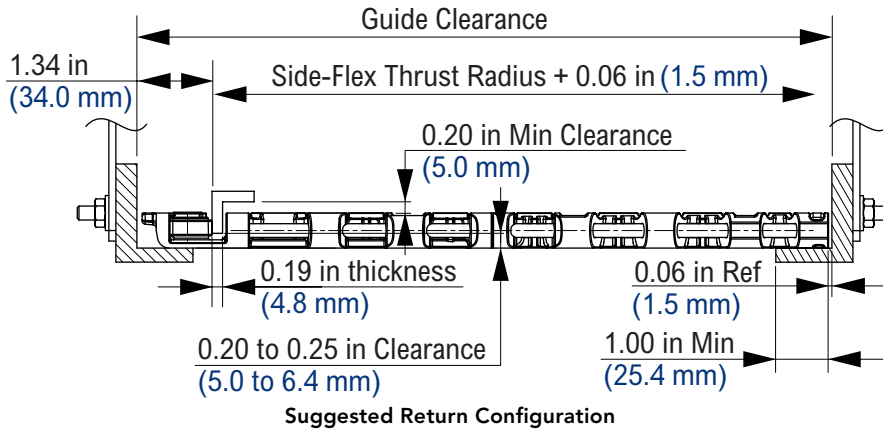

## Guide Clearance

Chain Width		Guide Clearance	
in	mm	in	mm
12	304.8	12.40	315.0
15	381.0	15.40	391.2
18	457.2	18.40	467.4
21	533.4	21.40	543.6
24	609.6	24.40	619.8
27	685.8	27.40	696.0
30	762.0	30.40	772.2
33	838.2	33.40	848.4
36	914.4	36.40	924.6

## C-Channel Profile Dimensions

	in	mm
Dimension A	0.75	19.1
Dimension B	1.25	31.8

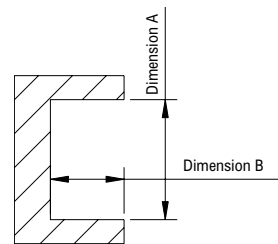

**C-Channel Profile**

# Drive and Idler

## End Drive and Idler Construction / Catenary

- The proper catenary is critical for performance, therefore a horizontal span of 18 to 24 in. (450 to 600 mm) and vertical sag of 3 to 6 in. (75 to 125 mm) is typically recommended. The catenary should be measured with the chain running
- Generally, take-up devices are NOT recommended. However, if a take-up must be used, a pneumatic type is preferred
- It is always recommended to minimize back-flexing. This results in decreased joint wear and extends chain life (i.e. utilize wear shoes with a generous radius)
- The lead-in shoe from the catenary sag to the return bed is recommended to have a 2 in. (50 mm) radius

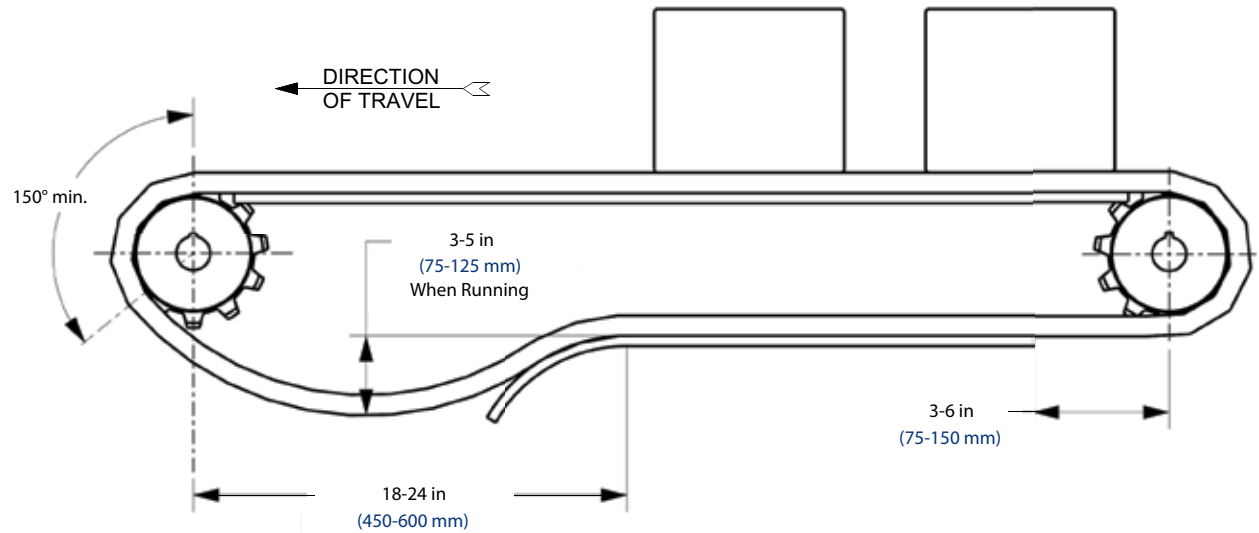

Catenary Sag Dimensions

**Note:** The inside radius of the chain may require a snubber roller to ensure proper wrap on the sprocket.

# Drive and Idler

## Bottom Drive Construction

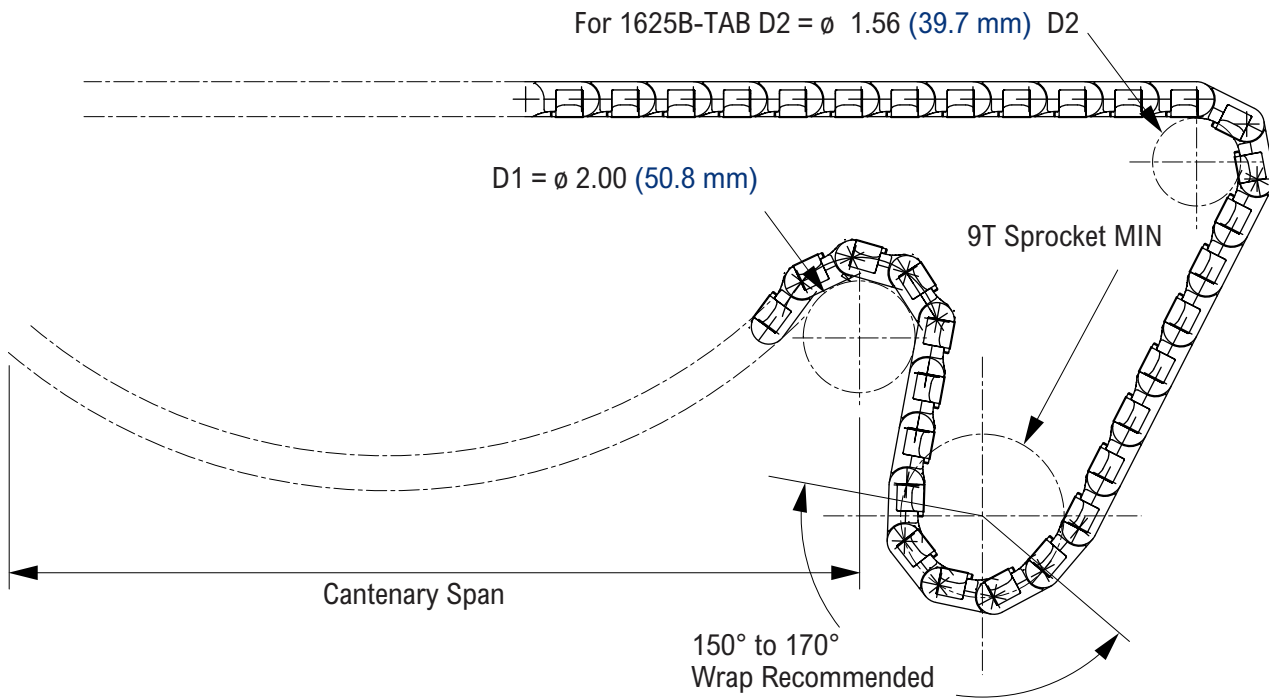

1625B-TAB Bottom Drive Configuration

# Drive and Idler

## Entry Radius

- Provide a generous entry radius to the return section which permits the chain to feed smoothly into the return ways
- The entry radius should be greater than the minimum back-flex radius of the chain. The back-flex radius of the 1625B-TAB MatTop Chain is 1.00 in. (25.4 mm), as shown on page 5

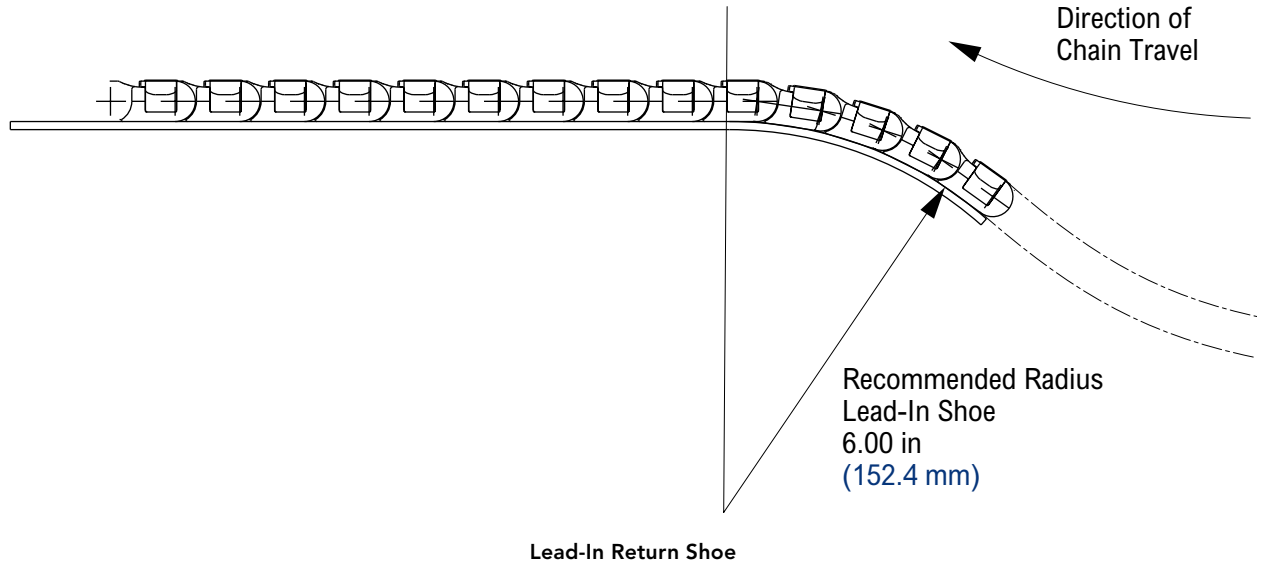

# Drive and Idler

## Drive Construction

Sprocket to wearstrip dimensions are shown below

Sprocket Size	Pitch Diameter		Outside Diameter		Dimension A		Dimension C		Dimension E	
	in	mm	in	mm	in	mm	in	mm	in	mm
NS7700-16	5.126	130.2	5.14	130.6	2.313	58.8				
NS7700-18	5.759	146.3	5.78	146.8	2.6295	66.8	1	25.4	0.25	6.4
NS7700-21	6.710	170.4	6.72	170.7	3.105	78.9				

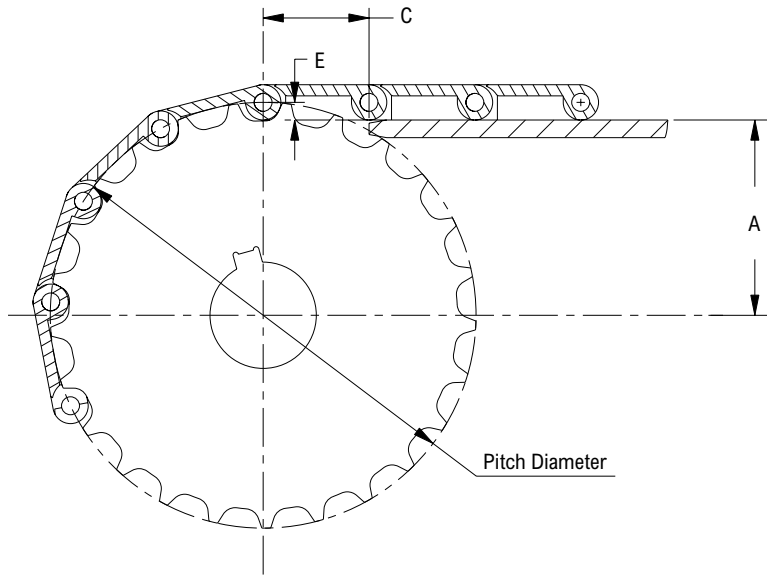

Sprocket and Wearstrip Dimensions

## Sprocket Location

- $A = (\text{Pitch Diameter} / 2) - E$
- $C = \text{One Chain Pitch (1.00 in. [25.4 mm])}$

## General Notes:

- Dimension C equals one chain pitch which ensures support under the chain at all times
- The leading edges of the wearstrips should be beveled

# Drive and Idler

## Sprocket Dimensions and Installation Notes

When installing sprockets, make sure all of the sprocket faces are positioned the same way on the shaft, with all identification marks facing the same direction (as shown). The timing notches in the teeth should be lined up along the length of the shaft.

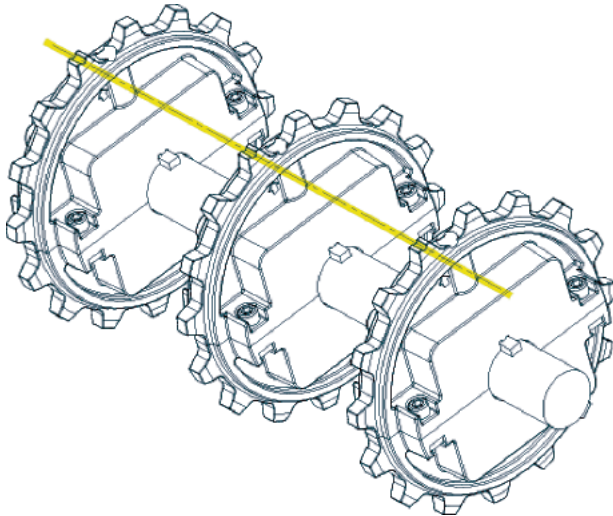

Sprockets Installed Correctly

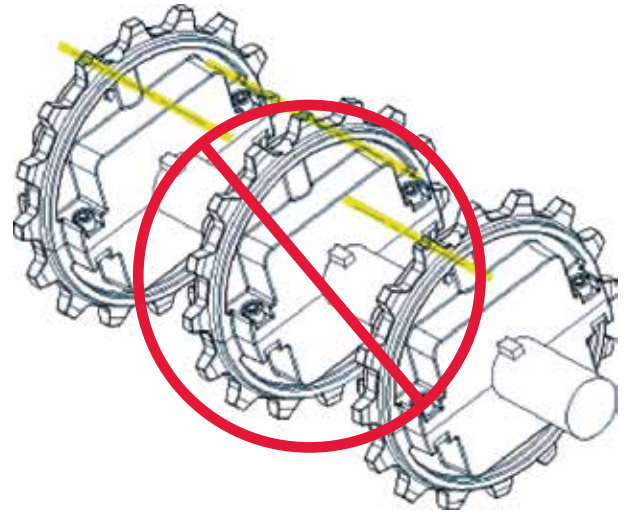

Sprockets Installed Incorrectly

## Sprocket Location

The 1625B-TAB MatTop Chain design requires 1 sprocket per 3 in. (76.2 mm) chain width as shown below.

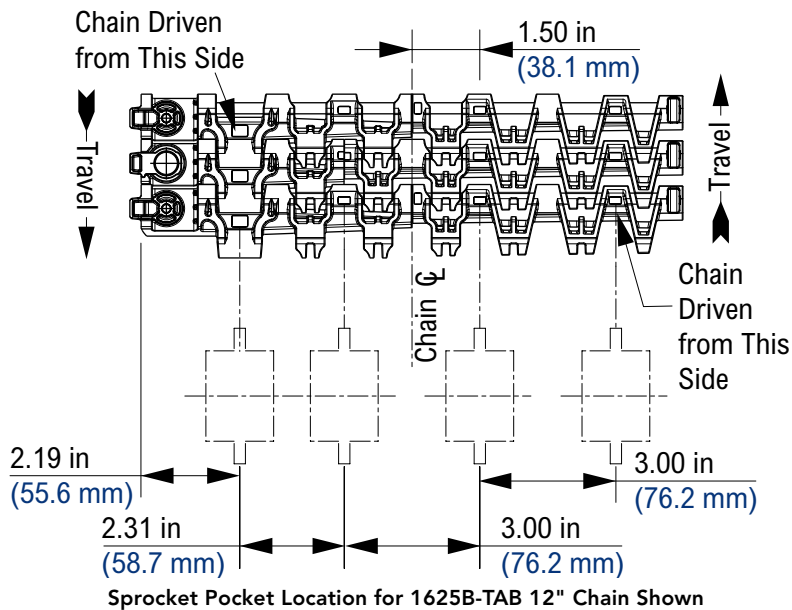

# Nose-Over Transfers

## Dynamic Nose-Roller Bar Dimensions

Rexnord recommends utilizing a dynamic nose-roller bar which uses a bearing/roller assembly captured in a bar to create a rolling surface instead of a sliding surface.

The rolling elements help to reduce wear on the bar and chain, which is especially critical on transfers of unstable product.

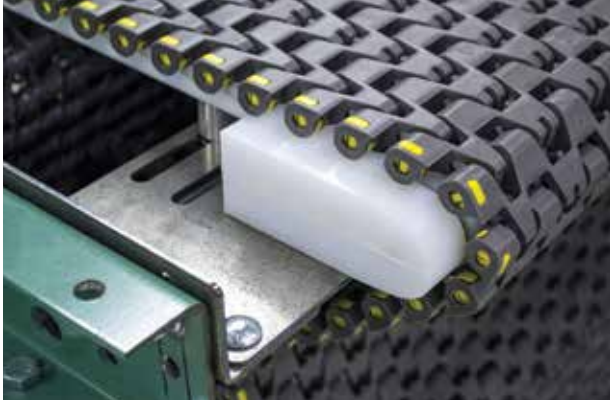

Dynamic Nose-Roller Bar

- The optimum nose-roller bar diameter is 1.56 in. (40 mm)
- The minimum distance between two nose-roller bar transfers is 3 in. (76.2 mm), as shown below

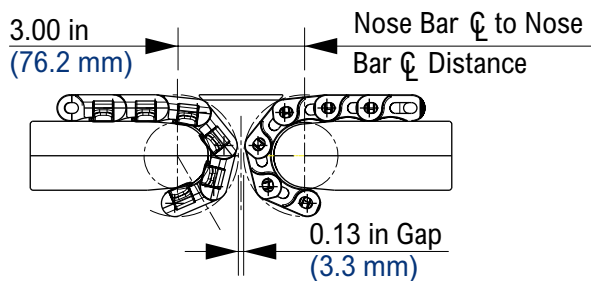

1625B-TAB Nose-Over Transfer Dimensions

- The dynamic nose-roller bar is available in a minimum width of 10.81 in. (274.5 mm) and can be bricked in increments of 3.00 in. (76.2 mm)
- Use standard 5/16 in. or M8 flat head screws (not included)
- The recommended wrap angle for maintaining good surface contact between chain and nose-roller bar is 135 degrees

# Nose-Roller Bars

## Nose-Roller Bar Mounting Dimensions

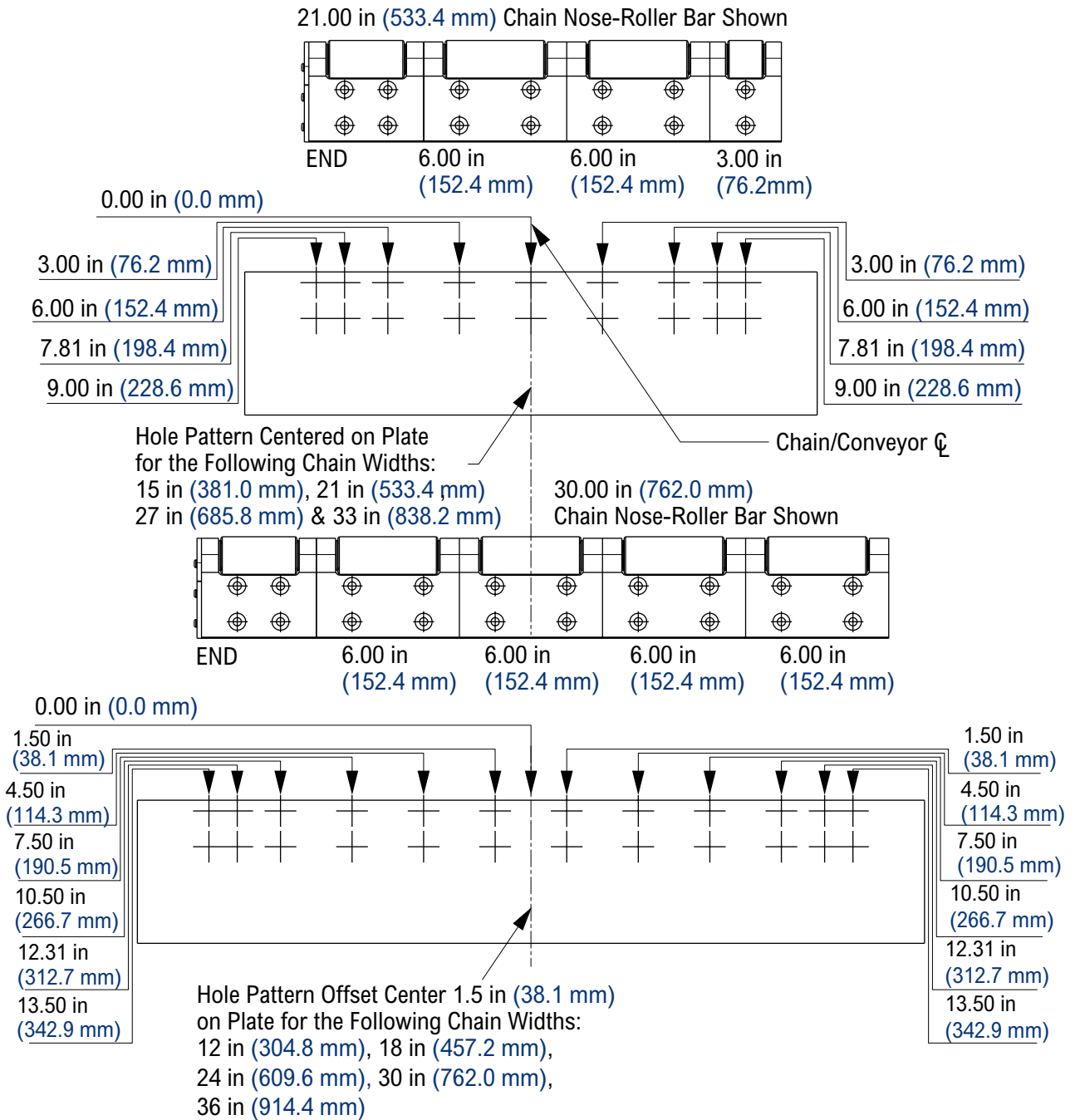

# Nose-Roller Bars

## Nose-Roller Bar Mounting Dimensions

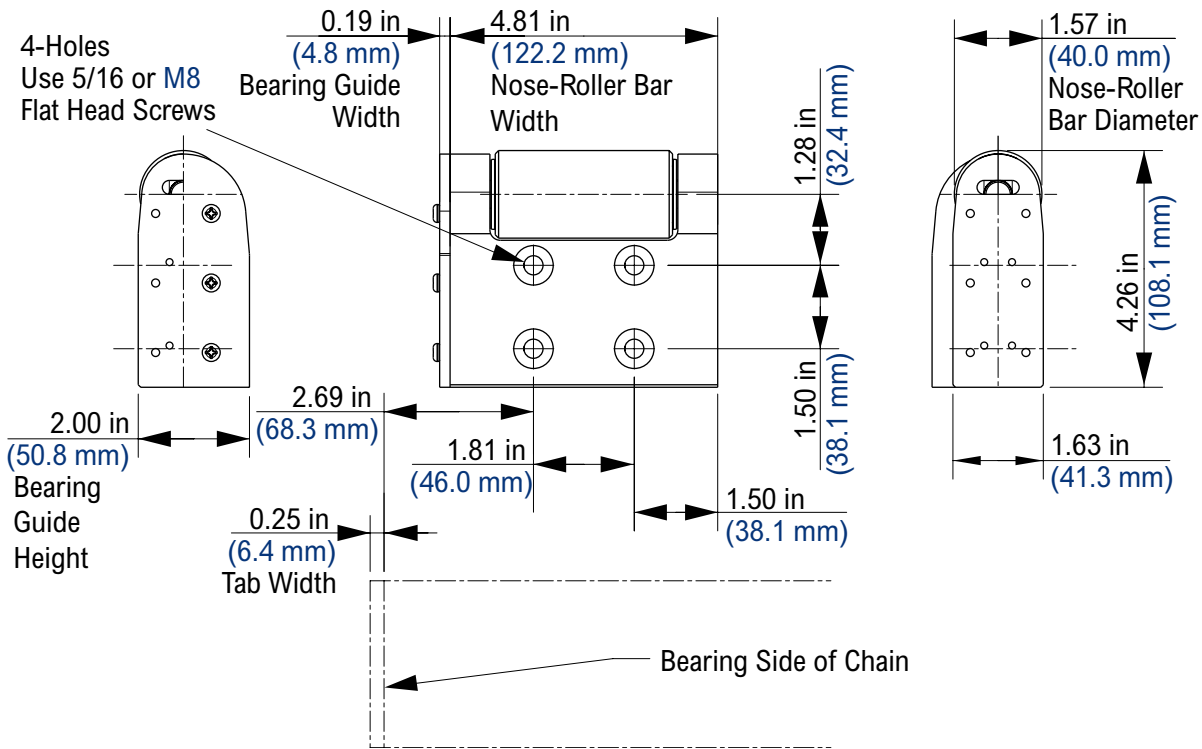

End Nose-Roller Bar Left-Hand

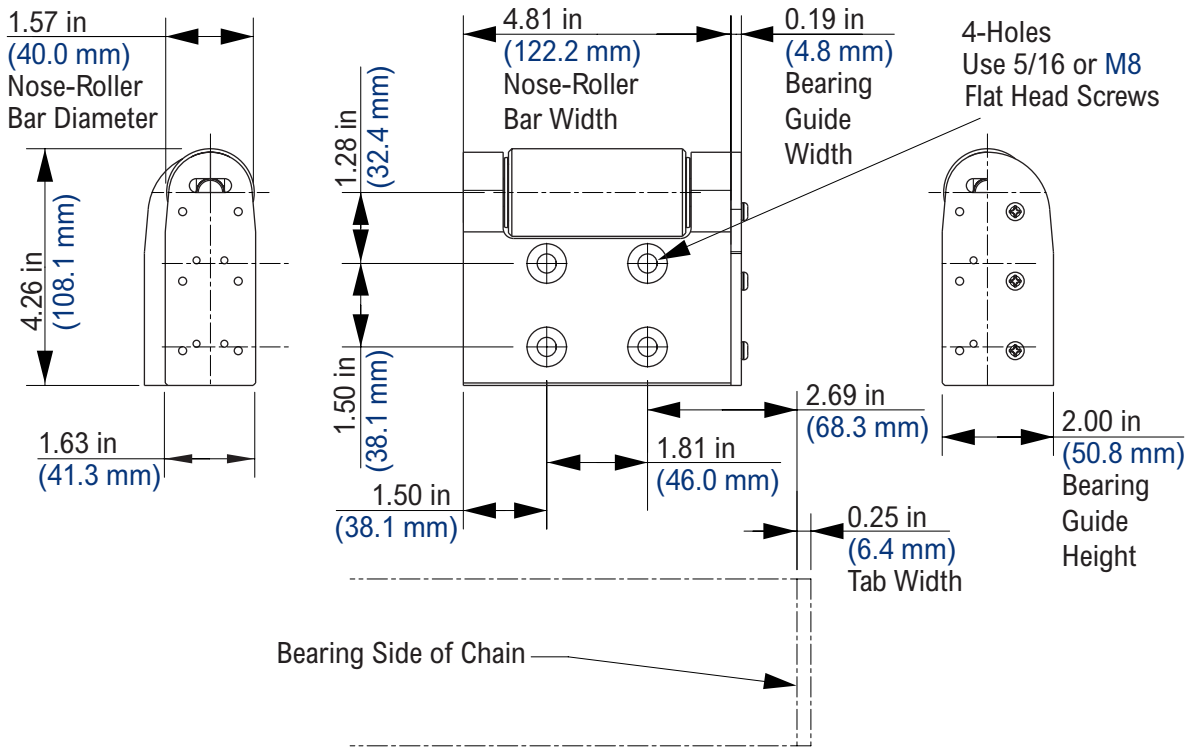

End Nose-Roller Bar Right-Hand

# Nose-Roller Bars

## Nose-Roller Bar Mounting Dimensions

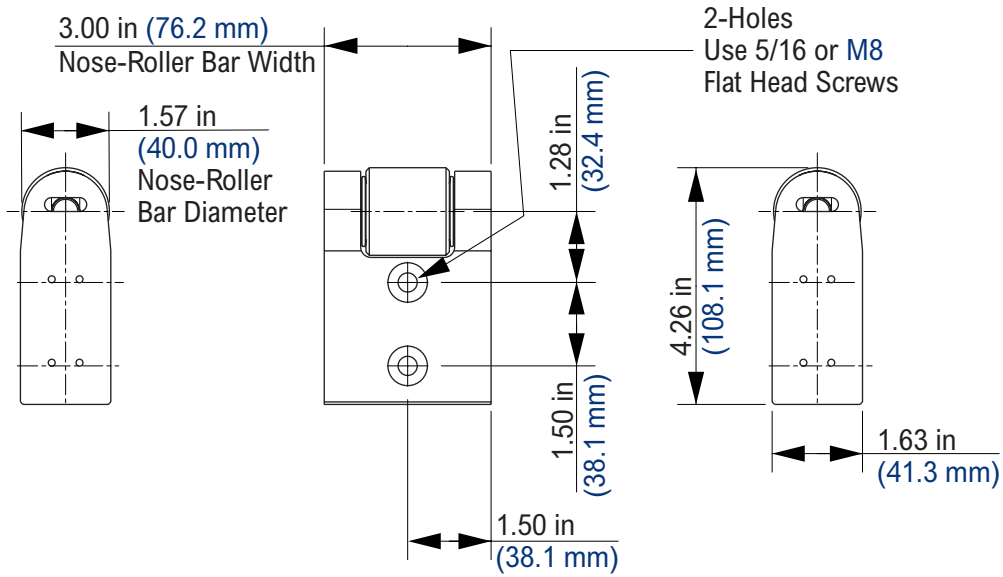

3 in (76.2 mm) Nose-Roller Bar

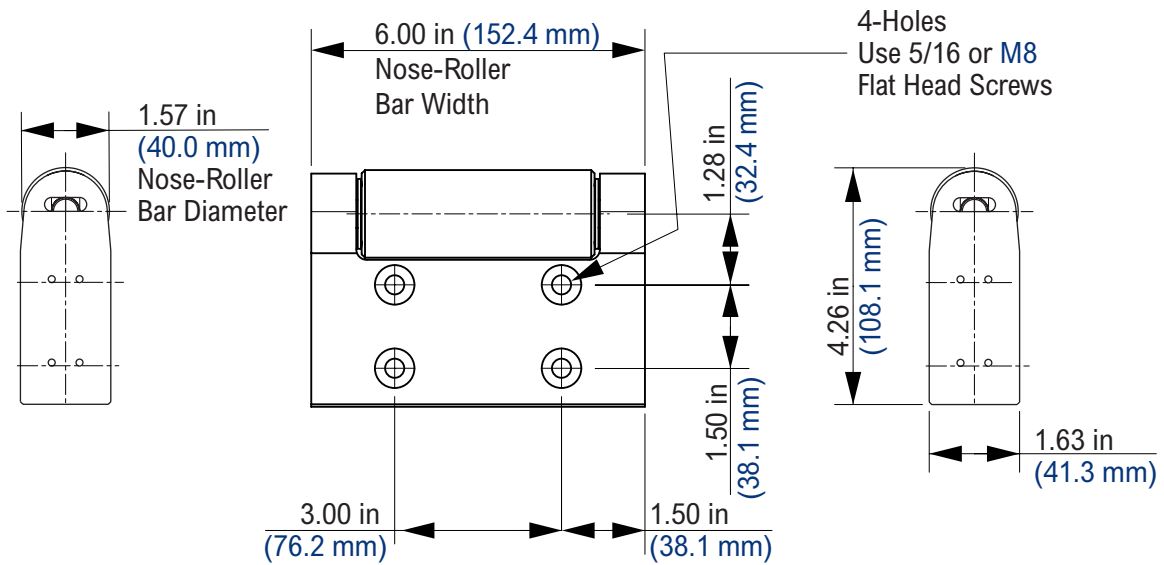

6 in (152.4 mm) Nose-Roller Bar

# Nose-Roller Bars

## Nose-Roller Bar Mounting Dimensions

- The table below shows the recommendations on the nose-roller bar widths per chain width
- The dynamic nose-roller bar is available in a minimum width of 10.81 in. (274.5 mm) and in increments of 3.00 in. (76.2 mm)

## Nose-Roller Bar Quantities per Conveyor End

Chain Width		Turn Direction	4.81 in (122.2 mm) End Nose-Roller with Bearing Guide Flange		6 in (152.4 mm) Nose-Roller		3 in (76.2 mm) Nose-Roller	
in	mm		Quantity	Part To Order	Quantity	Part To Order	Quantity	Part To Order
12	304.8	LH	1	10355789	1	10355801	0	10355787
15	381.0		1		1			
18	457.2		1		2			
21	533.4		1		2			
24	609.6		1		3			
27	685.8		1		3			
30	762.0		1		4			
33	838.2		1		4			
36	914.4		1		5			
12	304.8		RH		1		10355790	
15	381.0	1		1				
18	457.2	1		2				
21	533.4	1		2				
24	609.6	1		3				
27	685.8	1		3				
30	762.0	1		4				
33	838.2	1		4				
36	914.4	1		5				

# Assembly and Disassembly

## Required tools:

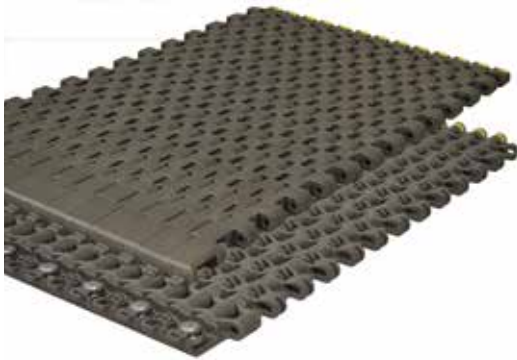

1625B-TAB Chain



Small Flat Screwdriver and Pin Puller

## Step 1 – Remove retention plug

Place small flat screwdriver under the edge of the retention plug and lift out as shown.

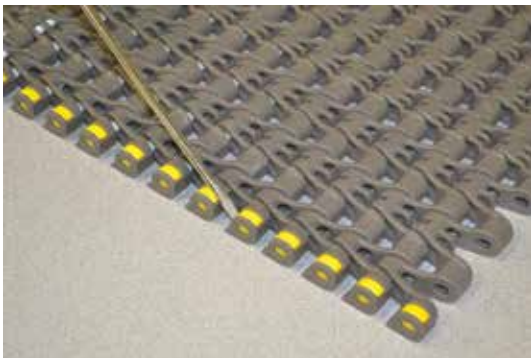

## Step 2 – Remove plastic pin

Use the pin puller to thread into the end of the plastic pin and pull the plastic pin out of the chain as shown. After the removal of the plastic pin, the chain can be separated.

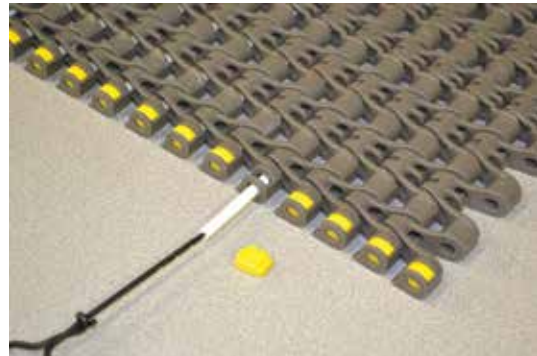
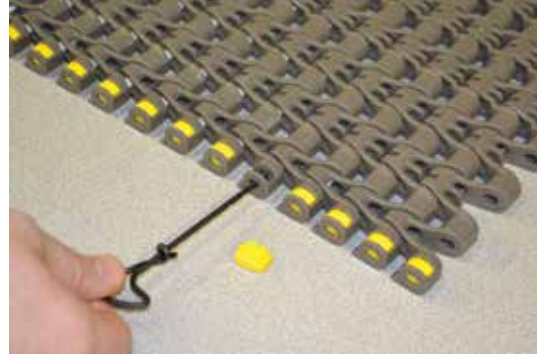

## General Assembly Notes

- Ensure bearing spacing is every other pitch if possible
- Visual inspection of installed chain prior to operation is recommended to ensure all components are properly assembled





866-REXNORD/866-739-6673 (Within the U.S.)  
414-643-2366 (Outside the U.S.)  
[www.rexnord.com](http://www.rexnord.com)

## Why Choose Rexnord?

When it comes to providing highly engineered products that improve productivity and efficiency for industrial applications worldwide, Rexnord is the most reliable in the industry. Commitment to customer satisfaction and superior value extend across every business function.

### Delivering Lowest Total Cost of Ownership

The highest quality products are designed to help prevent equipment downtime and increase productivity and dependable operation.

### Valuable Expertise

An extensive product offering is accompanied by global sales specialists, customer service and maintenance support teams, available anytime.

### Solutions to Enhance Ease of Doing Business

Commitment to operational excellence ensures the right products at the right place at the right time.

# REXNORD

## Rexnord Company Overview

Rexnord is a growth-oriented, multi-platform industrial company with leading market shares and highly trusted brands that serve a diverse array of global end markets.

## Process & Motion Control

The Rexnord Process & Motion Control platform designs, manufactures, markets and services specified, highly engineered mechanical components used within complex systems where our customers' reliability requirements and the cost of failure or downtime are extremely high.

## Water Management

The Rexnord Water Management platform designs, procures, manufactures and markets products that provide and enhance water quality, safety, flow control and conservation.